

- Cross-check valve as standard

Built-in cross check valve within motor protects the motor and bearing from damage caused by abrupt shutdown of hydraulic flow. And it also eliminates the need for a case drain

- Valve pack as standard

Flow control valve (priority flow divider) regulates hydraulic in-flow to the motor and prevents it from over-speeding. Thus, the compactor can be installed on carrier not equipped with a flow control valve on its auxiliary plumbing

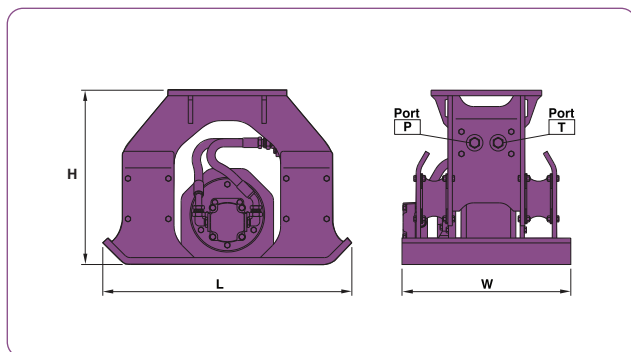

Adapter mount style (Flat Top) - PA series

	Weight	Baseplate size	Impulse Force	Vibrations	Carrier Weight Class
	Adaptor mount type kg	w x l mm	tonne	per minute	tonne
PHC050 Narrow	261	320 x 745	2.1	2100	4 - 6
PHC050 General	341	500 x 800	2.1	2100	4 - 6
PHC100	430	610 x 900	4	2000	6 - 13
PHC150	689	740 x 1050	6.4	2000	11 - 20
PHC200	1094	860 x 1200	11.2	2000	17 - 27
PHC300	1502	1000 x 1300	17.3	2000	26 - 40

